

Claw Couplings

from Pennine Industrial Equipment

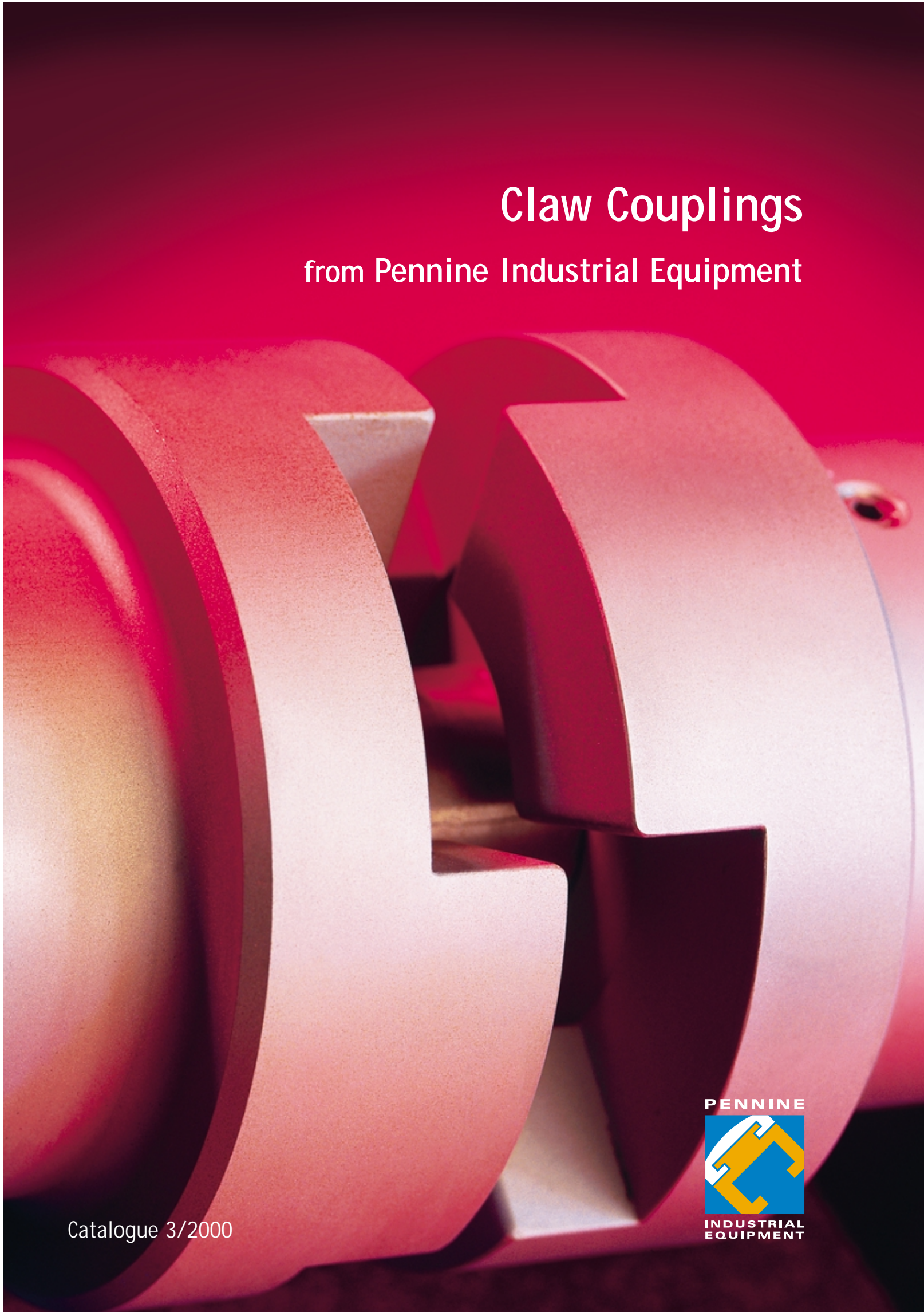

Catalogue 3/2000



Claw Couplings

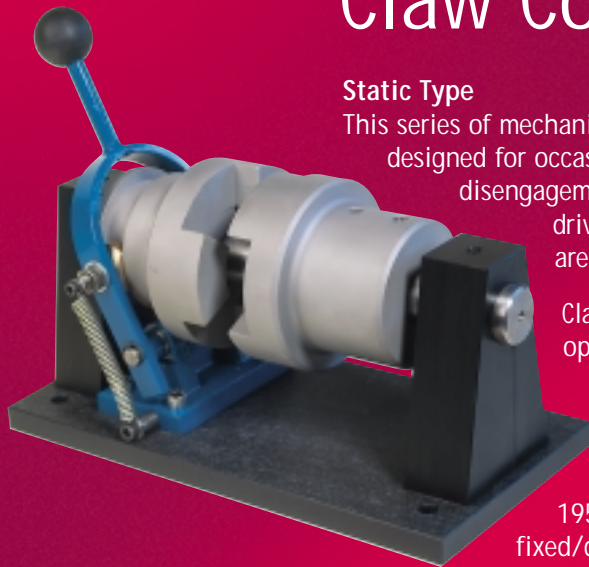

Static Type

This series of mechanical clutches are designed for occasional engagement and disengagement of transmission drives when the shafts are stationary.

Claw couplings for static operation are available in 15 standard sizes to fit shafts up to 155mm diameter on the sliding/driving half and 195mm diameter on the fixed/driven half.

These couplings are manufactured from 080M40 (En8) steel and are precision machined all over. The teeth are precision machined to ensure that the coupling will engage correctly in any position. Special couplings, which are designed to engage in one position only, can be manufactured on request.

Please note that due to the precise fit of teeth, which ensures no backlash or vibration when engaged, the shafts must be perfectly aligned to allow smooth engagement of the coupling.

The standard coupling has a sliding (driving) half which is engaged and disengaged by the handle operating mechanism. This half is fitted with a self-lubricating liner bush to allow easier sliding on the shaft.

The handle operating mechanism is spring loaded and can be adjusted to suit each application. It can also be supplied for pneumatic or hydraulic operation.

In some instances a 'lead-in' can be machined on the teeth to allow for easier engagement – consult Pennine for further details.

These couplings are bi-directional.

Coupling Selection

To determine the size of coupling required firstly select the smallest coupling that will accommodate the shaft sizes to be used. Then check the torque capacity of the selected coupling against the actual torque to be transmitted. If the selected coupling does not have a greater capacity than the actual torque to be transmitted move up to the first available size that will transmit the required torque.

Rotating type

Also available are a series of claw couplings known as 'rotating' type. The angled teeth on this series of couplings allow the coupling to engage even when the teeth are not directly in line. These couplings are uni-directional and will disengage when reversed. This range of couplings is capable of transmitting torques from 176Nm to 206KNm. For more details on this range please contact Pennine.



Size	Max. torque (KNm)	Max. shaft dia.	Max. speed
DA180R	0.18	35	3200
DA200R	0.30	42	2900
DA225R	0.60	50	2600
DA250R	1.00	60	2300
DA280R	1.75	70	2000
DA315R	3.25	85	1800
DA355R	5.90	100	1600
DA400R	11.00	120	1450
DA450R	19.60	145	1300
DA500R	34.30	170	1150
DA560R	60.80	210	1000
DA630R	108.00	240	900
DA710R	206.00	290	800



CLAW COUPLINGS for STATIC OPERATION

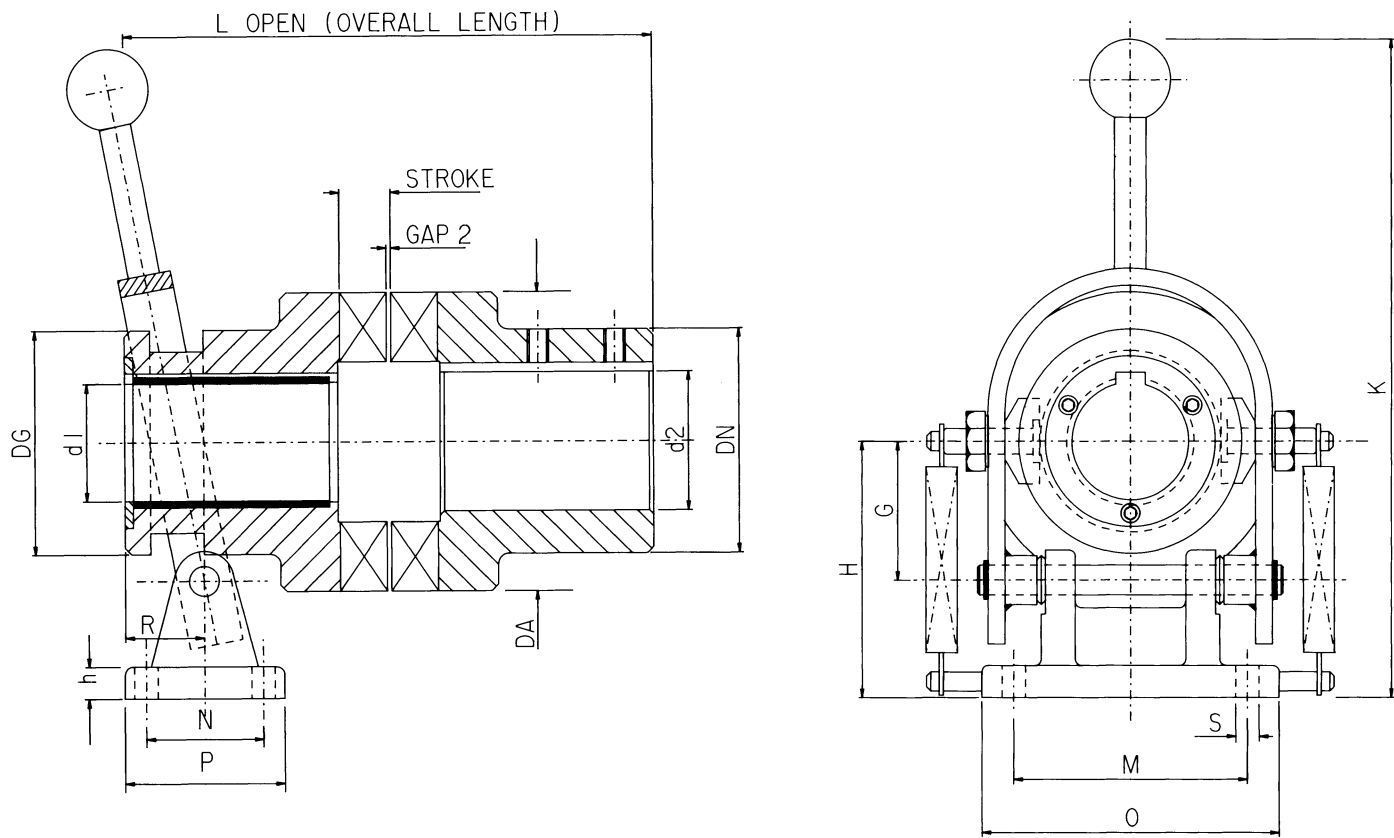

Size (Denote S after size)
Torque max
Shaft size max.

DA	Md Nm	d1	d2	DG	DN	D	B	a	c	x	y	L	L1	z	G	H	M	N	O	P	h	s	R	Stroke	K	No. of Claws
80	196	32	40	65	65	50	70	16	6	14	30	142	55	16	48	78	90	35	110	55	12	9	22	16	218	3
90	294	35	45	70	70	55	81	18	8	15	32	164	65	17	52	82	90	35	110	55	12	9	26	17	227	3
100	392	40	50	75	75	60	92	20	8	16	36	186	75	18	53	85	90	35	110	55	12	9	27	18	238	3
112	540	45	55	85	85	64	99	20	10	18	40	200	80	20	55	100	95	50	120	75	15	11	30	20	265	3
125	834	50	60	95	95	75	111	20	10	20	45	224	90	22	58	113	95	50	120	75	15	11	31	22	288	3
140	1177	55	65	105	105	85	123	25	12	22	50	248	100	24	65	120	110	55	140	80	15	11	37	24	310	3
160	2943	60	75	125	125	95	142	25	12	25	55	286	115	29	76	136	125	55	150	80	15	11	38	27	356	4
180	4120	70	85	135	135	105	155	30	15	28	60	312	125	32	80	145	150	60	185	90	20	13	45	30	390	4
200	5886	80	95	150	150	120	169	30	15	32	70	340	135	36	90	160	150	60	185	90	20	13	47	34	415	4
225	8240	90	105	170	170	130	193	30	20	36	80	388	155	40	100	170	170	65	210	105	20	13	54	38	440	6 max
250	11280	100	120	185	185	145	212	30	20	40	90	384	170	44	109	179	170	65	210	105	20	13	56	42	464	6 max
280	15500	110	130	200	200	160	242	35	25	45	100	486	195	49	116	196	210	75	250	110	20	17	66	47	506	6 max
315	31392	125	150	225	225	185	262	35	25	50	110	526	210	54	131	216	240	80	280	120	20	19	70	52	556	8 max
355	44145	140	170	260	260	220	292	40	30	55	120	529	235	59	151	236	285	100	335	140	20	21	79	57	621	8 max
400	61800	155	195	320	320	270	317	45	30	60	140	636	255	64	185	270	330	110	375	150	25	21	84	62	720	8 max

If Gap is increased then R dimension should be compensated accordingly, as this formula: $R = c + \frac{(a + x + GAP)}{2}$

The figures shown in the tables are based on the shear strength of the driving shaft and keyway which is the only calculation required on a static claw coupling.

All shaft sizes shown are the maximum available in the Coupling. Couplings can be supplied with any bore and keyway in metric or imperial sizes up to the maximum shown. DN can be increased to suit larger bore requirements.

In certain instances the teeth can have angled edge to offer a lead-in and better engagement of the coupling.

Couplings can be supplied with or without an operating handle assembly.

Other products offered by
Pennine Industrial Equipment
include



PENNINE



**INDUSTRIAL
EQUIPMENT**

Pennine Industrial Equipment Ltd
Manor Croft House, Commercial Road, Skelmanthorpe,
Huddersfield, West Yorkshire, UK, HD8 9DT
Tel: +44 (0) 1484 864733 Fax: +44 (0) 1484 865235
E-mail: sales@pennine.org
Web: www.pennine.org